

03S

3-JAW SOLID POWER CHUCK

三爪中实动力卡盘



尺寸图 Dimensions

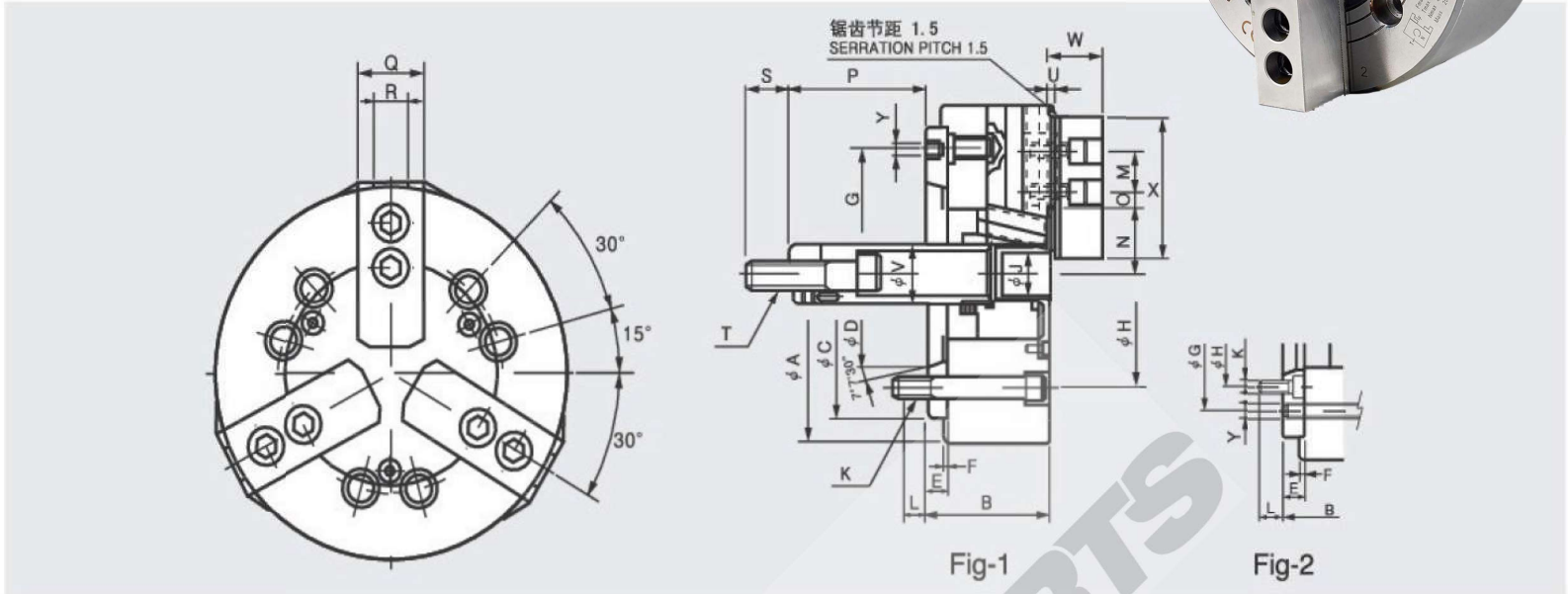

规格表 Specification

单位/UNT:mm

型号 Model	主轴鼻端 番号	A	B	C (h6)	D	E	F	G	H	J	K	L	M	N (max)
03S05	A2-4	135	55	80	-	-	7	-	100	-	3-M8	19	-	30.4
03S06	A2-5	165	84	140	82.536	15	5	116	104.8	21	6-M10	19	20	37.8
03S08	A2-6	210	97	170	106.375	17	5	150	133.4	25	6-M12	18	25	46.3
03S10A06	A2-6	254	109	220	106.375	25	5	171.4	133.4	34	6-M12	18.5	30	51.1
03S10A08	A2-8	254	102	220	139.719	18	5	190	171.4	34	6-M16	25	30	51.1
03S12A06	A2-6	304	125	220	106.375	25	6	171.4	133.4	34	6-M12	18	30	61
03S12A08	A2-8	304	118	220	139.719	18	6	190	171.4	34	6-M16	25	30	61

型号 Model	N (min)	O (max)	O (min)	P (max)	P (min)	Q	R	S	T	U	V	W	X	Y
03S05	27.2	17.1	9.6	9	-6	25	10	35	M12X1.75	2	28	31	62	-
03S06	33.5	15.1	9.1	86.5(101.5)	66.5 (81.5)	31	12	36	M16x2.0	4	34	39	73	3-M6
03S08	41.9	22.25	11.75	110(127)	89 (106)	35	14	36	M20x2.5	5	38	42	95	3-M6
03S10A06	46.7	30.75	11.25	133(158)	108(133)	40	16	36	M20x2.5	5	45	46	110	6-M16
03S10A08	46.7	30.75	11.25	140(158)	115(133)	40	16	36	M20x2.5	5	45	46	110	3-M8
03S12A06	55.75	48.75	12.75	138(163)	108(133)	49	18	36	M20x2.5	5	50	53.5	129	6-M16
03S12A08	55.75	48.75	12.75	145(163)	115(133)	49	18	36	M20x2.5	5	50	53.5	129	3-M8

型号 Model	夹持直径 Grip Dia (mm)		爪行程 Jaw stroke (mm)	柱塞行程 Plunger Stroke (mm)	最大拉力 Max. pull force		最高回转速度 Max. speed r.p.m.(min ⁻¹)	净重 Weight (kg)	搭配 油压缸型号 Operating Cylinder	最大设定油压压力 Max. hydr pressure		工作 硬爪 Operating HARD JAW
	max	min			kgf	(KN)				kg/cm ²	(Mpa)	
03S05	135	8	6.4	15	7.8 (800)	24 (2450)	5500	6	RH-80	2.5 (25)	HJ-05	
03S06	165	18	8.5	20	18 (1835)	52.5 (5353)	5270	14	RH-100	2.6 (26.5)	HJ-06	
03S08	210	12	8.8	21	25 (2549)	75 (7648)	4760	27	RH-125	2.5 (25.5)	HJ-08	
03S10A06	254	16	8.8	25	29 (2957)	108 (11013)	4010	40	RH-125	2.8 (28.6)	HJ10	
03S10A08	254	16	8.8	25	29 (2957)	108 (11013)	4010	40	RH-125	2.8 (28.6)	HJ10	
03S12A06	304	18	10.5	30	41 (4181)	156 (15907)	3380	67	RH-150	2.7 (27.5)	HJ12	
03S12A08	304	18	10.5	30	41 (4181)	156 (15907)	3380	66	RH-150	2.7 (27.5)	HJ12	