

# 5069# SD3-60/80 鑽孔主軸頭 Drilling Head Units

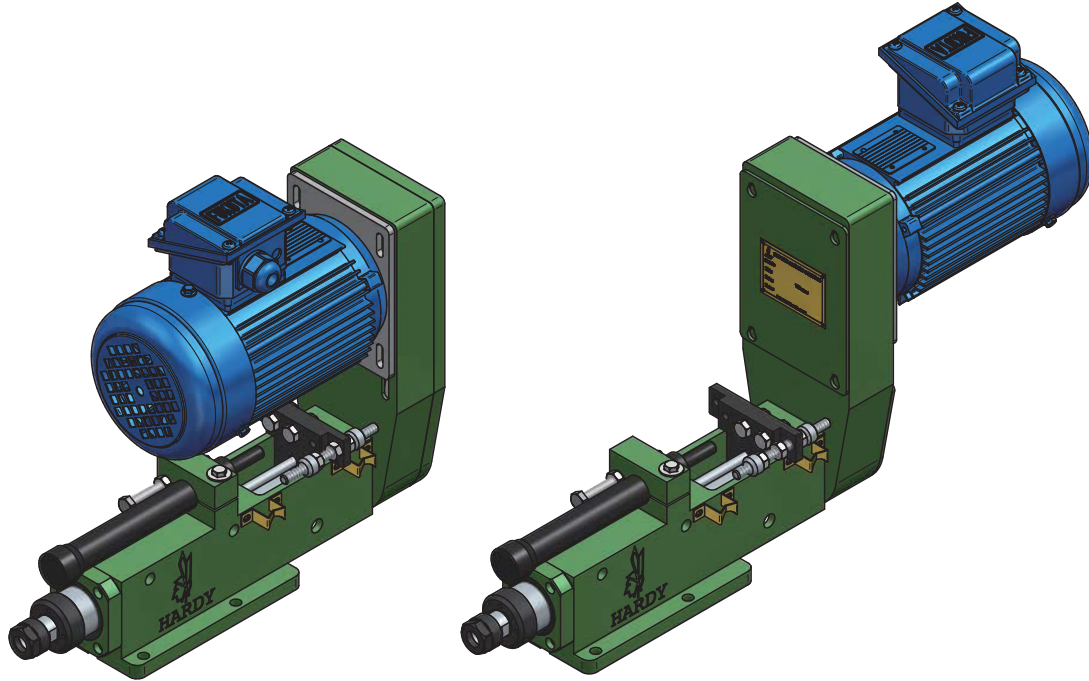

穩速器可選配美製 - 白馬牌

| 規 格   | Model                    | SD3-60  | SD3-80 | SD3A-55                       | SD3A-75 |
|-------|--------------------------|---|--------|-------------------------------|---------|
| 鑽孔能力  | Drilling Capacity (S45C) | φ 6 mm  |        |                               |         |
| 最大行程  | Max. Stroke              | 60mm  | 80mm   | 55mm                          | 75mm    |
| 最高轉速  | Max. RPM                 | 10000 RPM   |        |                               |         |
| 推進壓力  | Propel Pressure          | 油壓 (H) 10~15 kg/cm <sup>2</sup>                           |        | 空壓 (A) 4~8 kg/cm <sup>2</sup> |         |
| 油缸面積  | Cylinder Diameter        | 前進 (F) 12.6 cm <sup>2</sup><br>後退 (B) 7.1 cm <sup>2</sup> |        |                               |         |
| 馬 力   | Horsepower, 3 Phase      | 1/2 HP, 220V/380V, 三相                                     |        |                               |         |
| 傳動皮帶  | Transmission Belt        | 5J - 200  |        |                               |         |
| 主軸軸承  | Spindle Bearing          | 6002ZZx4  |        |                               |         |
| 皮帶輪軸承 | Pulley Bearing           | 6002ZZx3  |        |                               |         |
| 前蓋油封  | Front Cover Seal         | TC40-50-8x1   |        | TC40-50-8x1                   |         |
| 活塞O型環 | Piston O-ring            | AP-326x2, AG-45x2, AG-40x2                                |        | UH40x2, AG-45x2, AG-40x1      |         |
| 前蓋O型環 | Front Cover O-ring       | TC30-40-7x1   |        |                               |         |
| 後蓋油封  | Back Cover Seal          | AG-45x2, UH30x1   |        | AG-45x1, AG-30x2              |         |
| 後蓋O型環 | Back Cover O-ring        | AG-45x1, AG-30x2  |        |                               |         |

Roundness: ≤0.003mm



# 5069# SD3-60 鑽孔主軸頭 Drilling Head Units

SD3-60-ER16-FL(左向) / FR(右向)  
SD3-60-JT1-FL(左向) / FR(右向)  
SD3-60-JT2-FL(左向) / FR(右向)  
SD3-60-KH14E-FL(左向) / FR(右向)

|    |        |       |
|----|--------|-------|
| 重量 | Weight | 21 kg |
|----|--------|-------|

穩速器可選配  
美製白馬牌

JT1 JT2

KH14E

ER16

SD3-60-ER16-BL(左向) / BR(右向)  
SD3-60-JT1-BL(左向) / BR(右向)  
SD3-60-JT2-BL(左向) / BR(右向)  
SD3-60-KH14E-BL(左向) / BR(右向)

|    |        |       |
|----|--------|-------|
| 重量 | Weight | 21 kg |
|----|--------|-------|

穩速器可選配  
美製白馬牌

JT1 JT2

KH14E

ER16



**HARDY**

## 5069# SD3-80 鑽孔主軸頭 Drilling Head Units

SD3-80-ER16-FL(左向) / FR(右向)  
SD3-80-JT1-FL(左向) / FR(右向)  
SD3-80-JT2-FL(左向) / FR(右向)

|    |        |       |
|----|--------|-------|
| 重量 | Weight | 21 kg |
|----|--------|-------|

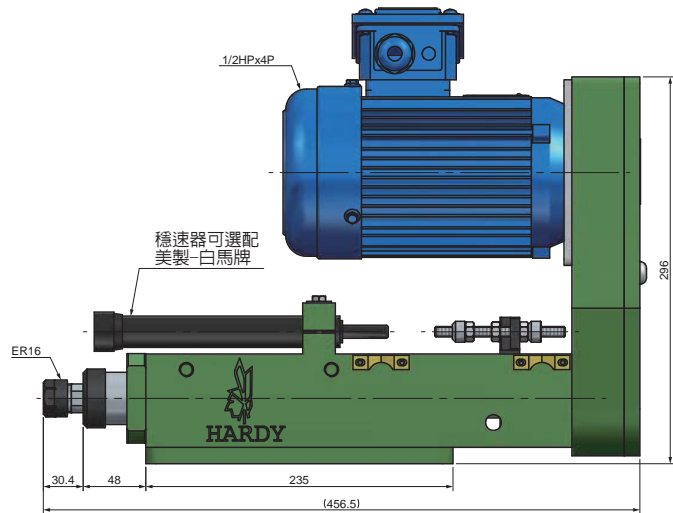
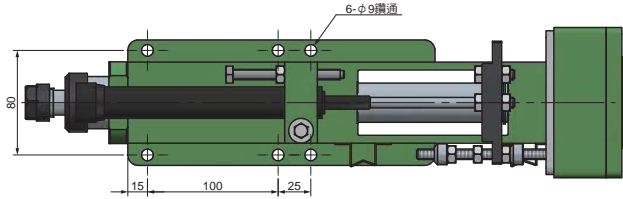
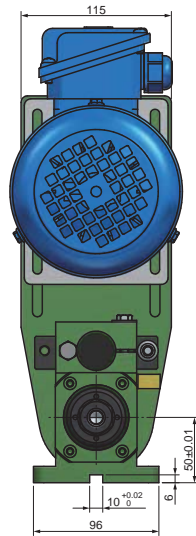
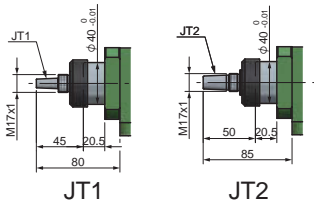
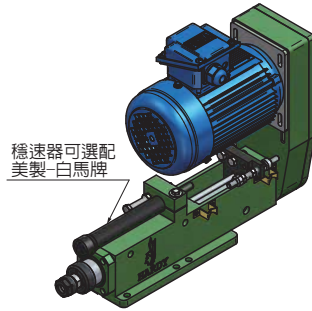

SD3-80-ER16-BL(左向) / BR(右向)  
SD3-80-JT1-BL(左向) / BR(右向)  
SD3-80-JT2-BL(左向) / BR(右向)

|    |        |       |
|----|--------|-------|
| 重量 | Weight | 21 kg |
|----|--------|-------|

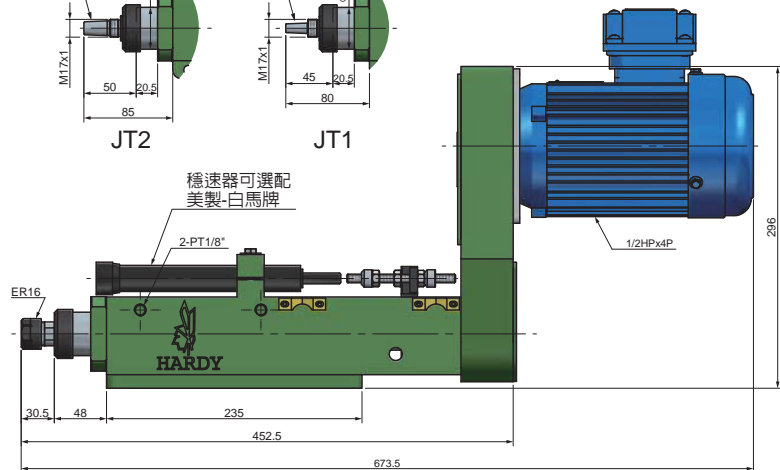
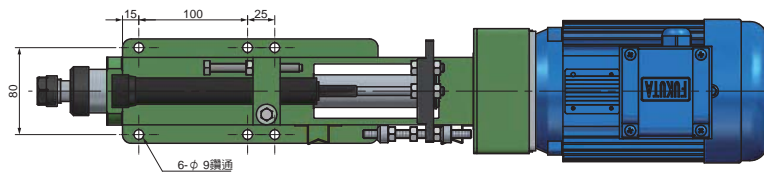
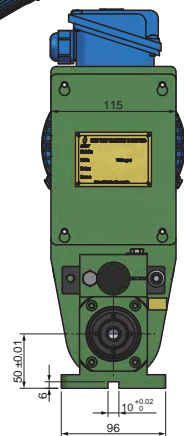
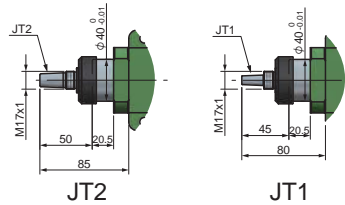
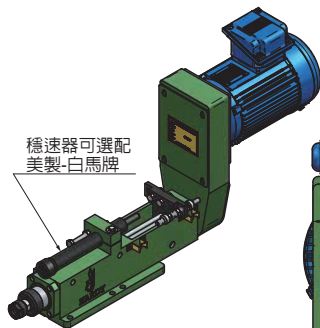

# 5069# SD3A-55 鑽孔主軸頭-空壓

## Drilling Head Units-Pneumatic

空壓Pneumatic SD3A-55-ER16-FL(左向) / FR(右向)  
 空壓Pneumatic SD3A-55-JT1-FL(左向) / FR(右向)  
 空壓Pneumatic SD3A-55-JT2-FL(左向) / FR(右向)  
 空壓Pneumatic SD3A-55-KH14E-FL(左向) / FR(右向)

|    |        |       |
|----|--------|-------|
| 重量 | Weight | 21 kg |
|----|--------|-------|

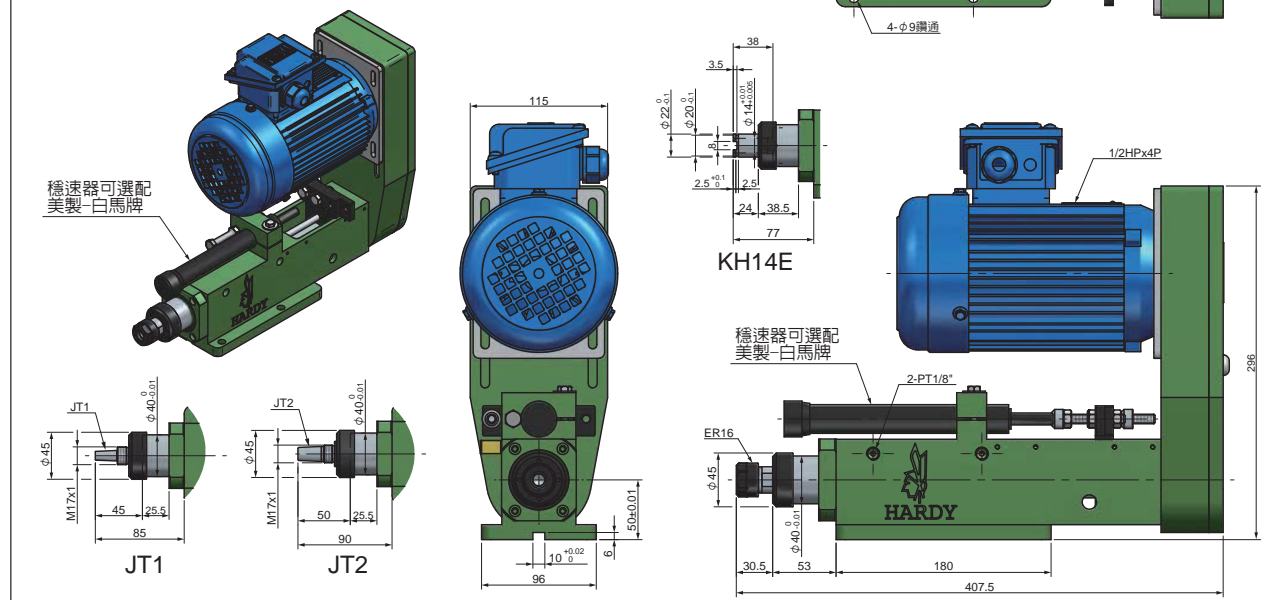

空壓Pneumatic SD3A-55-ER16-BL(左向) / BR(右向)  
 空壓Pneumatic SD3A-55-JT1-BL(左向) / BR(右向)  
 空壓Pneumatic SD3A-55-JT2-BL(左向) / BR(右向)  
 空壓Pneumatic SD3A-55-KH14E-BL(左向) / BR(右向)

|    |        |       |
|----|--------|-------|
| 重量 | Weight | 21 kg |
|----|--------|-------|

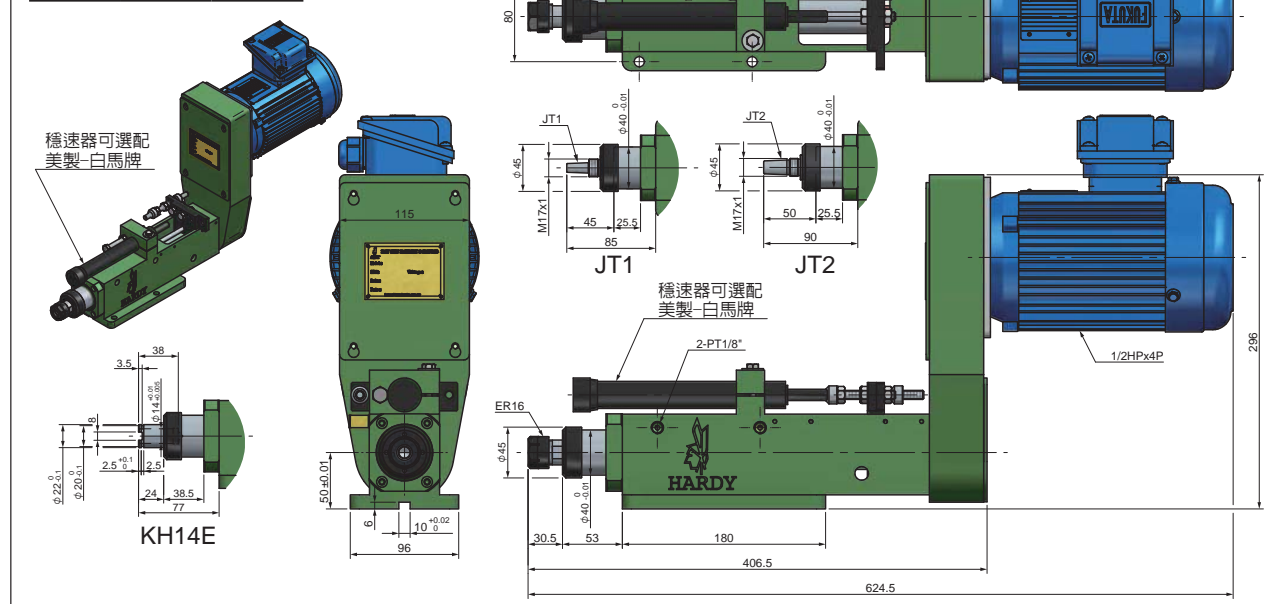



## 5069# SD3A-75 鑽孔主軸頭-空壓 Drilling Head Units-Pneumatic

空壓Pneumatic SD3A-75-ER16-FL(左向) / FR(右向)  
 空壓Pneumatic SD3A-75-JT1-FL(左向) / FR(右向)  
 空壓Pneumatic SD3A-75-JT2-FL(左向) / FR(右向)

|    |        |       |
|----|--------|-------|
| 重量 | Weight | 21 kg |
|----|--------|-------|

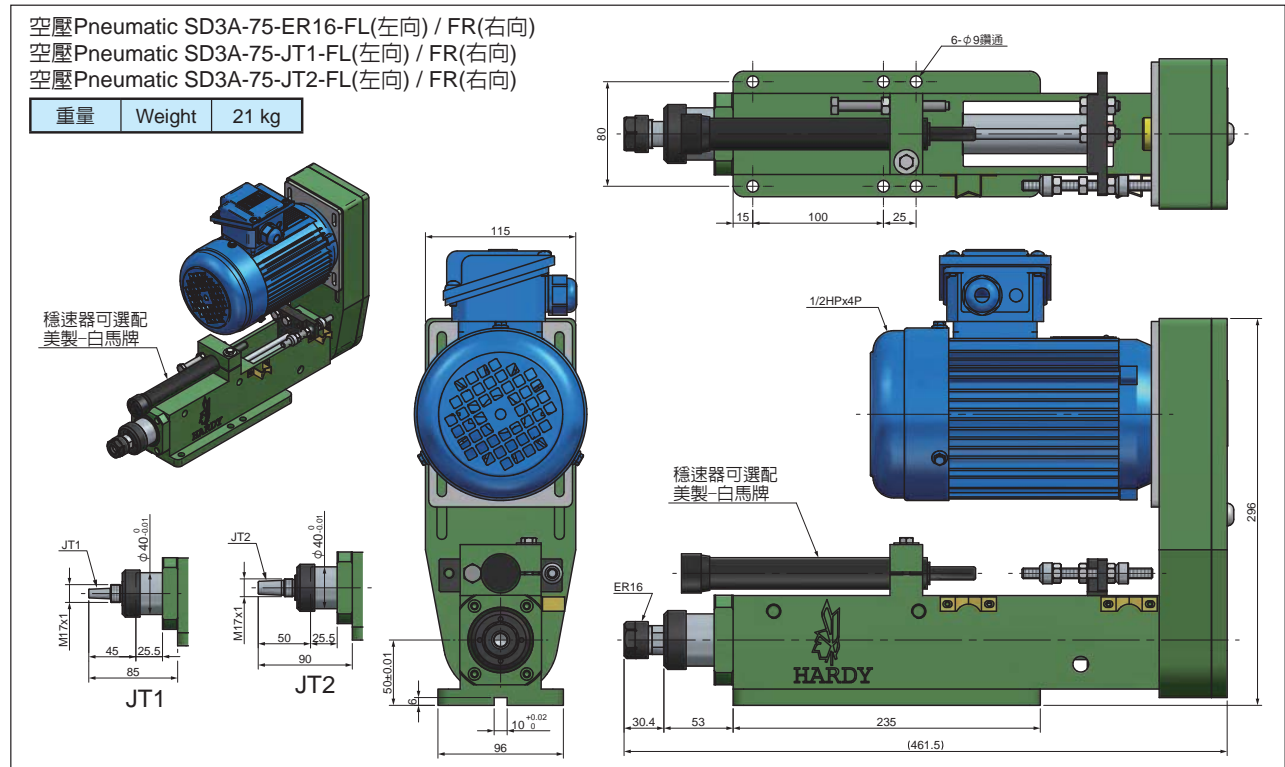

空壓Pneumatic SD3A-75-ER16-BL(左向) / BR(右向)  
 空壓Pneumatic SD3A-75-JT1-BL(左向) / BR(右向)  
 空壓Pneumatic SD3A-75-JT2-BL(左向) / BR(右向)

|    |        |       |
|----|--------|-------|
| 重量 | Weight | 21 kg |
|----|--------|-------|

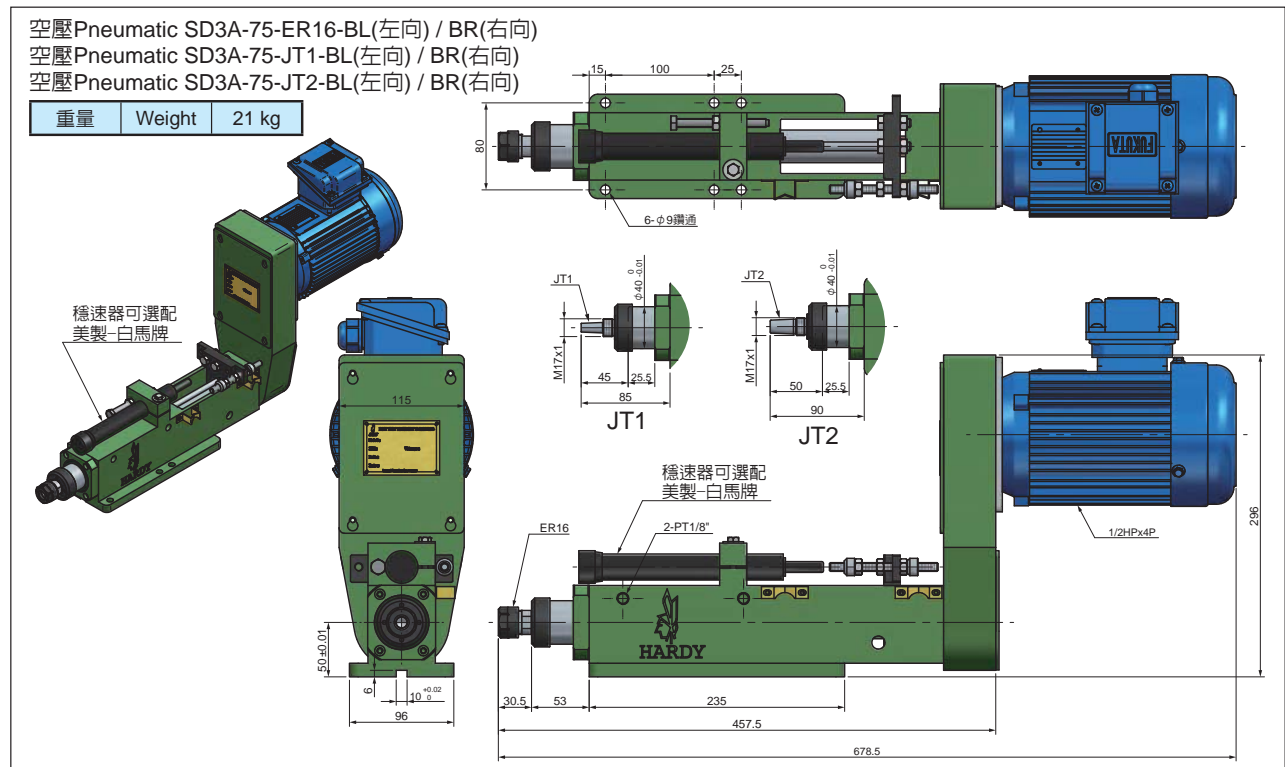

## 5070# SD5-85 鑽孔主軸頭 Drilling Head Units



穩速器可選配美製 - 白馬牌

| 規 格   | Model                    | SD5-85   | SD5A-80                              |
|-------|--------------------------|--|--------------------------------------|
| 鑽孔能力  | Drilling Capacity (S45C) | φ 13mm   |                                      |
| 最大行程  | Max. Stroke              | 85mm   | 80mm                                 |
| 最高轉速  | Max. RPM                 | 5000 RPM   |                                      |
| 推進壓力  | Propel Pressure          | 油壓 (H) 20~25 kg/cm <sup>2</sup>                            | 空壓 (A) 4~8 kg/cm <sup>2</sup>        |
| 油缸面積  | Cylinder Diameter        | 前進 (F) 21.5 cm <sup>2</sup><br>後退 (B) 11.5 cm <sup>2</sup> |                                      |
| 馬 力   | Horsepower, 3 Phase      | 1HP, 220V/380V   |                                      |
| 傳動皮帶  | Transmission Belt        | 5M - 615   |                                      |
| 主軸軸承  | Spindle Bearing          | 6004ZZx4   |                                      |
| 皮帶輪軸承 | Pulley Bearing           | 6203ZZx3   |                                      |
| 前蓋油封  | Front Cover Seal         | DKB 50-62-10x1   |                                      |
| 活塞O型環 | Piston O-ring            | AP-53x3  | UHA-53x2                             |
| 前蓋O型環 | Front Cover O-ring       | AG-58x2, AP-50x2<br>AG-68x1                                | AG-58x2, AP-50x1<br>AG-50x1, AG-68x1 |
| 後蓋油封  | Back Cover Seal          | TC35-45-8x1  |                                      |
| 後蓋O型環 | Back Cover O-ring        | AG-58x2<br>UH-35-45-6x1                                    | AG-58x2<br>UHA-35-45-6x1             |

Roundness: ≤0.003mm



**HARDY**

## 5070# SD5-85 鑽孔主軸頭 Drilling Head Units

油壓Hydraulic SD5-85-ER20-FL(左向) / FR(右向)  
油壓Hydraulic SD5-85-JT6-FL(左向) / FR(右向)

|    |        |       |
|----|--------|-------|
| 重量 | Weight | 39 kg |
|----|--------|-------|

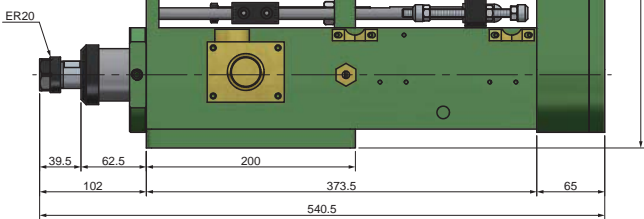
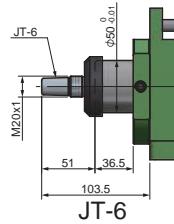
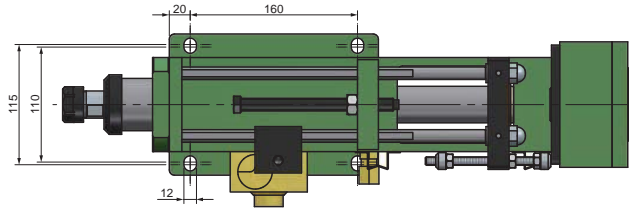
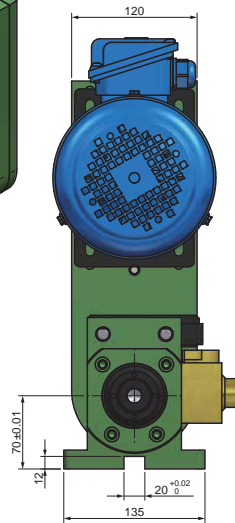
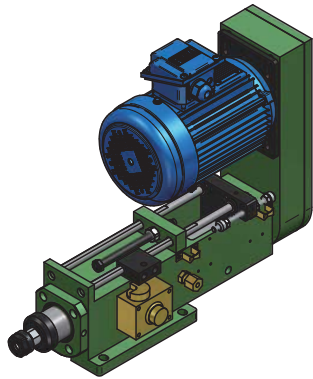

油壓Hydraulic SD5-85-ER20-BL(左向) / BR(右向)  
油壓Hydraulic SD5-85-JT6-BL(左向) / BR(右向)

|    |        |       |
|----|--------|-------|
| 重量 | Weight | 39 kg |
|----|--------|-------|

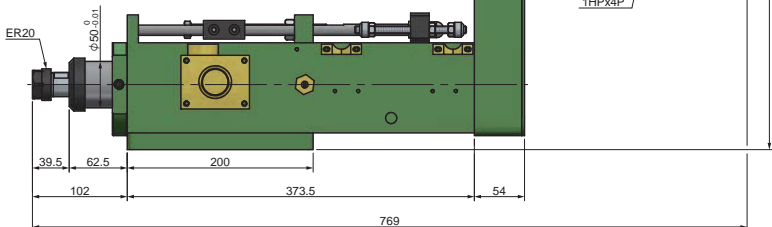
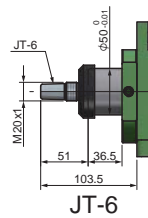
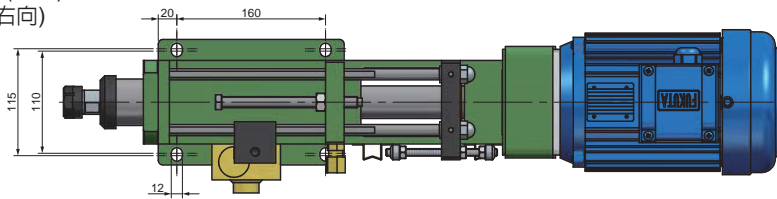
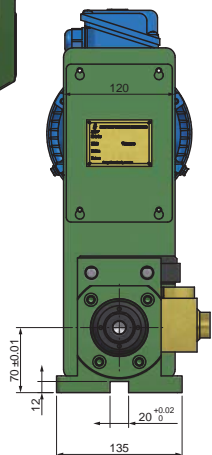
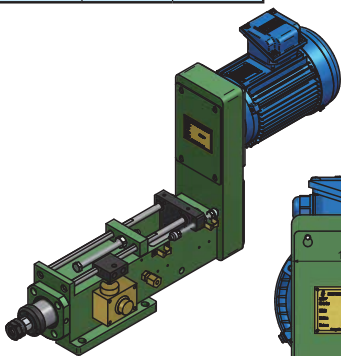

# 5070# SD5A-80 鑽孔主軸頭-空壓

## Drilling Head Units-Pneumatic

空壓Pneumatic SD5A-80-ER20-FL(左向) / FR(右向)  
 空壓Pneumatic SD5A-80-JT6-FL(左向) / FR(右向)

|    |        |       |
|----|--------|-------|
| 重量 | Weight | 39 kg |
|----|--------|-------|

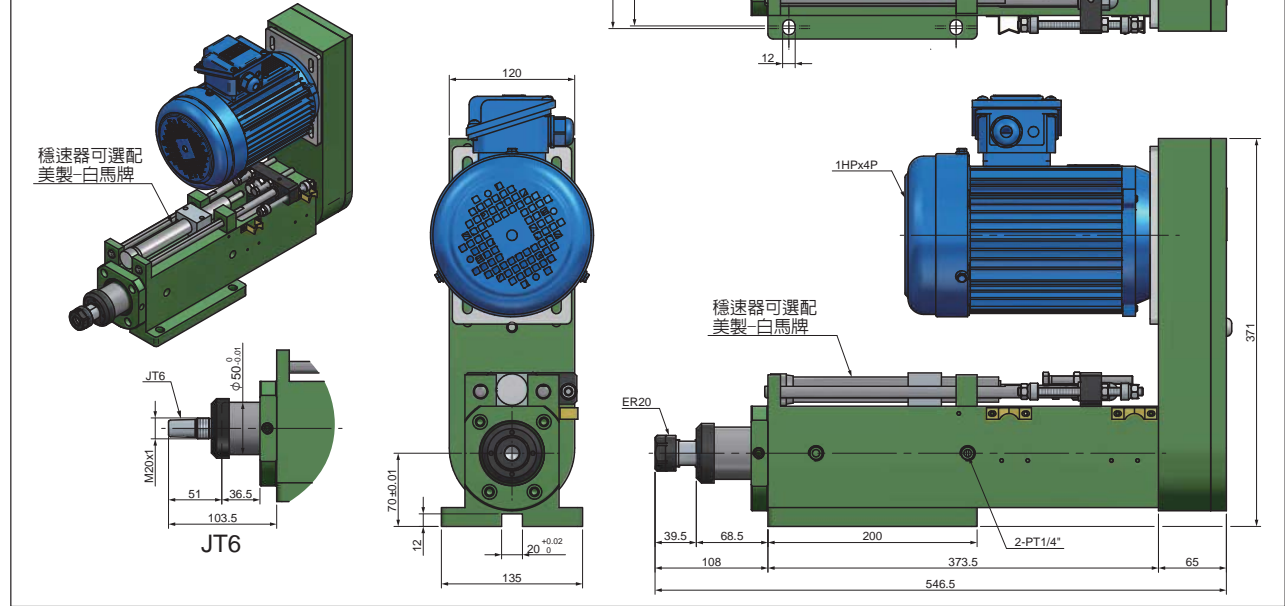

空壓Pneumatic SD5A-80-ER20-BL(左向) / BR(右向)  
 空壓Pneumatic SD5A-80-JT6-BL(左向) / BR(右向)

|    |        |       |
|----|--------|-------|
| 重量 | Weight | 39 kg |
|----|--------|-------|

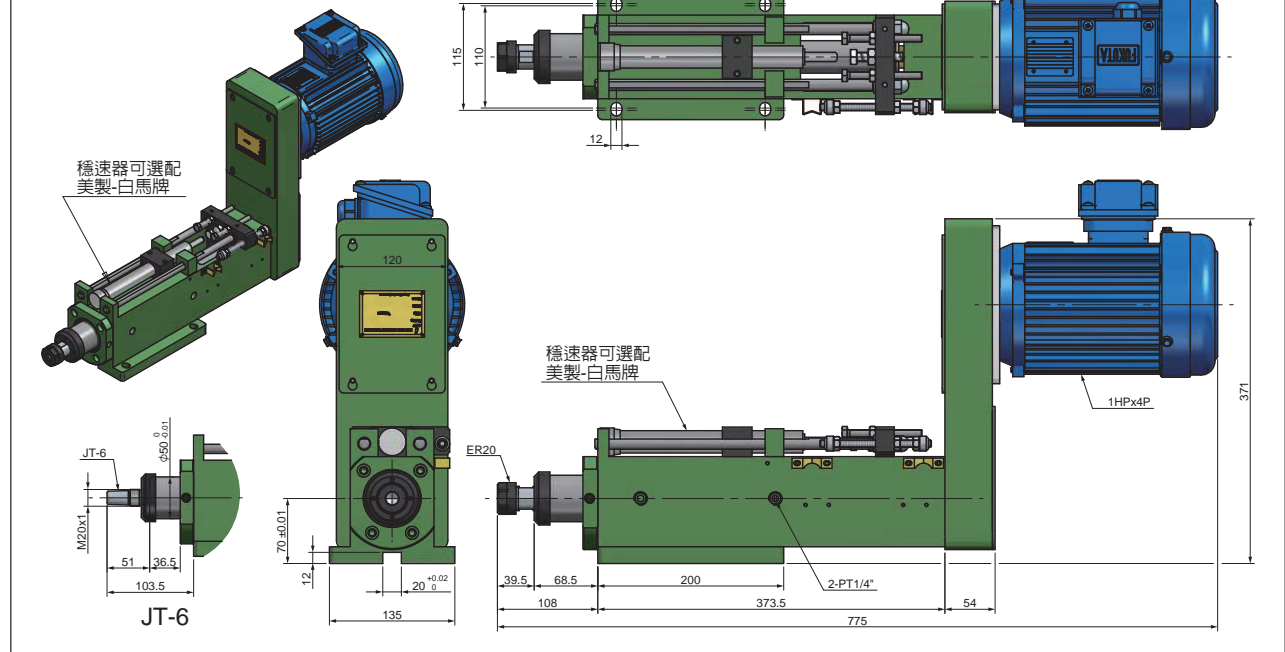



## 5071# SD7-130 鑽孔主軸頭 Drilling Head Units



馬達板型組合

|       |                          |  |
|-------|--------------------------|--|
| 規格    | Model                    | SD7-130  |
| 鑽孔能力  | Drilling Capacity (S45C) | φ 20 mm  |
| 最大行程  | Max. Stroke              | 130 mm   |
| 最高轉速  | Max. RPM                 | 2500 RPM   |
| 推進壓力  | Propel Pressure          | 油壓 (H) 20~30 kg/cm <sup>2</sup>                          |
| 油缸面積  | Cylinder Diameter        | 前進 (F) 37 cm <sup>2</sup><br>後退 (B) 15.9 cm <sup>2</sup> |
| 馬力    | Horsepower, 3 Phase      | 1 HP, 220V / 380V  |
| 傳動皮帶  | Transmission Belt        | A2×φ 100, 8M×40T×50W                                     |
| 主軸軸承  | Spindle Bearing          | 6004Z, 32004<br>6005Z, 32005                             |
| 皮帶輪軸承 | Pulley Bearing           | 6008Z, 51208   |
| 前蓋油封  | Front Cover Seal         | TC60-70-10×1   |
| 活塞O型環 | Piston O-ring            | AP-65×2, AG-35×1, TC32-52-10×1                           |
| 前蓋O型環 | Front Cover O-ring       | AP-60×2, AG-70×1, AG-80×1                                |
| 後蓋O型環 | Back Cover O-ring        | AP-30×2, AG-70×1, AG-80×1                                |

Roundness: ≤0.003mm

# 5071# SD7-130 鑽孔主軸頭 Drilling Head Units

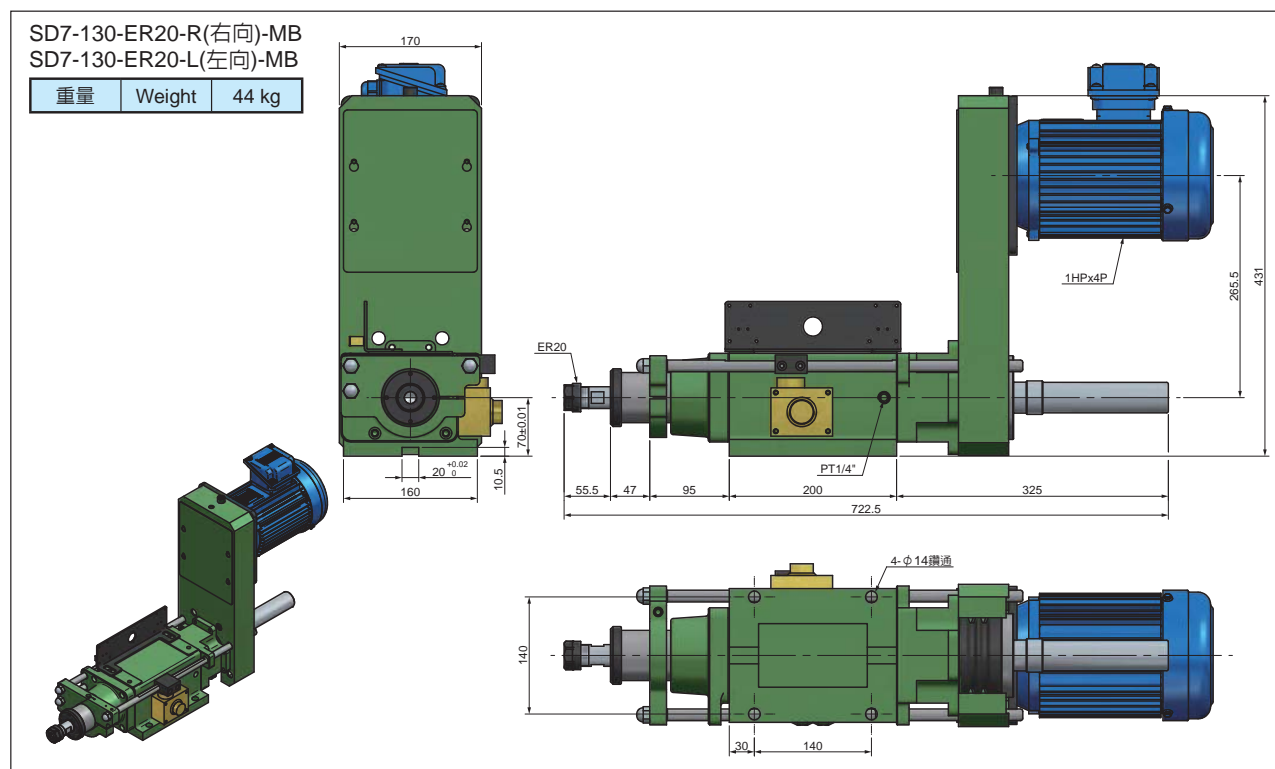
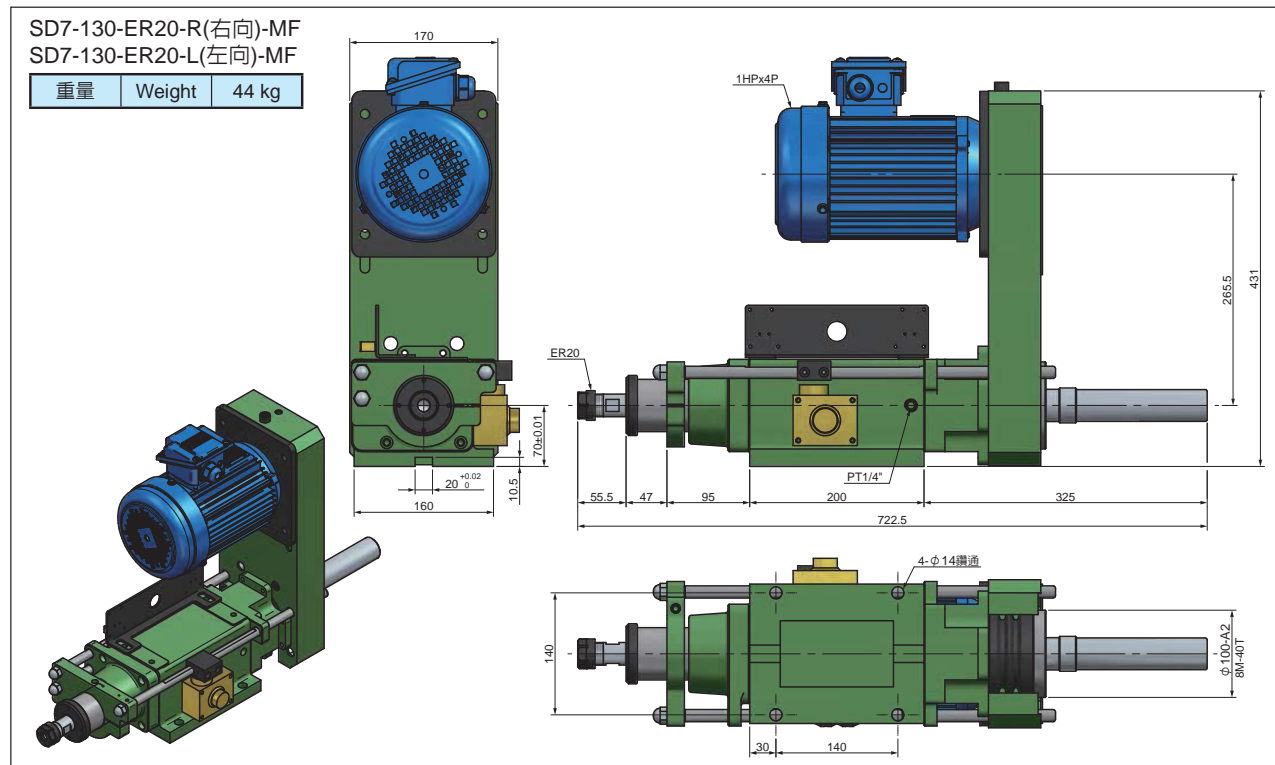



**HARDY**

## 5071# SD7-130 鑽孔主軸頭 Drilling Head Units

SD7-130-ER20-AR(右向)  
SD7-130-ER20-AL(左向)

|    |        |       |
|----|--------|-------|
| 重量 | Weight | 54 kg |
|----|--------|-------|

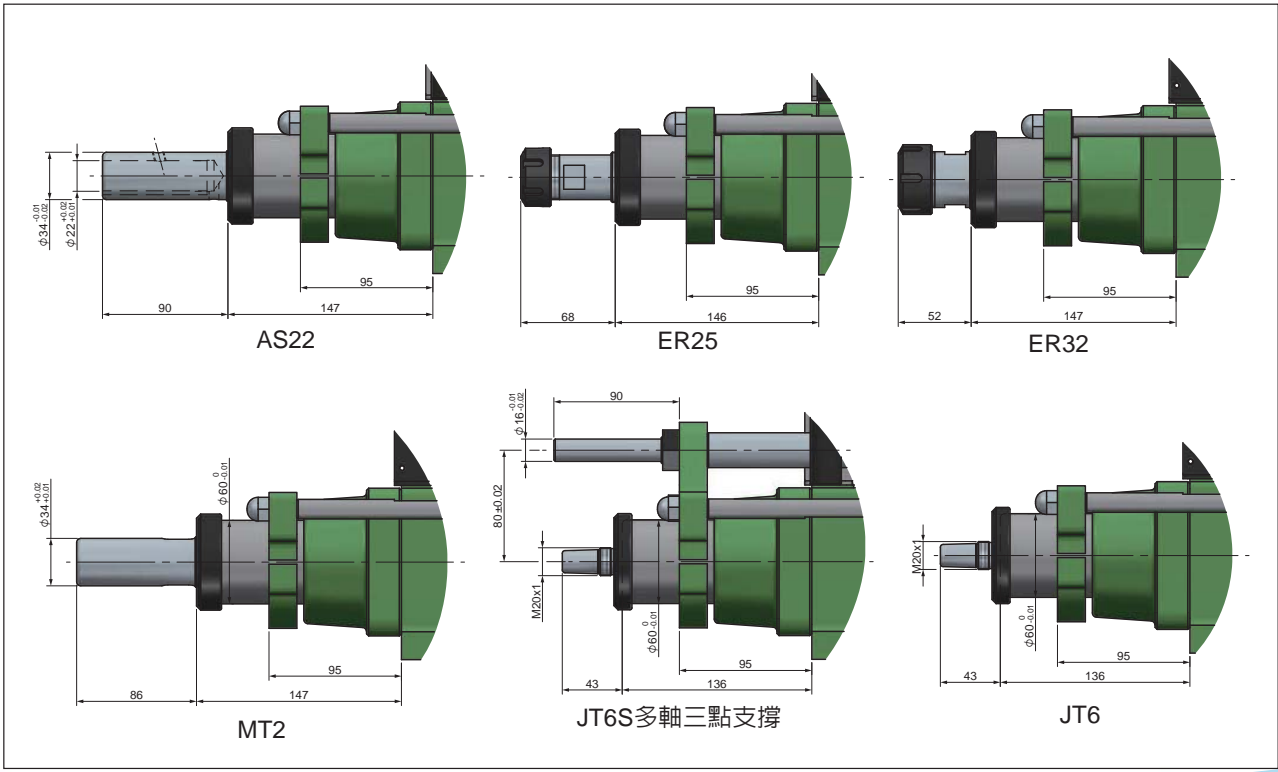
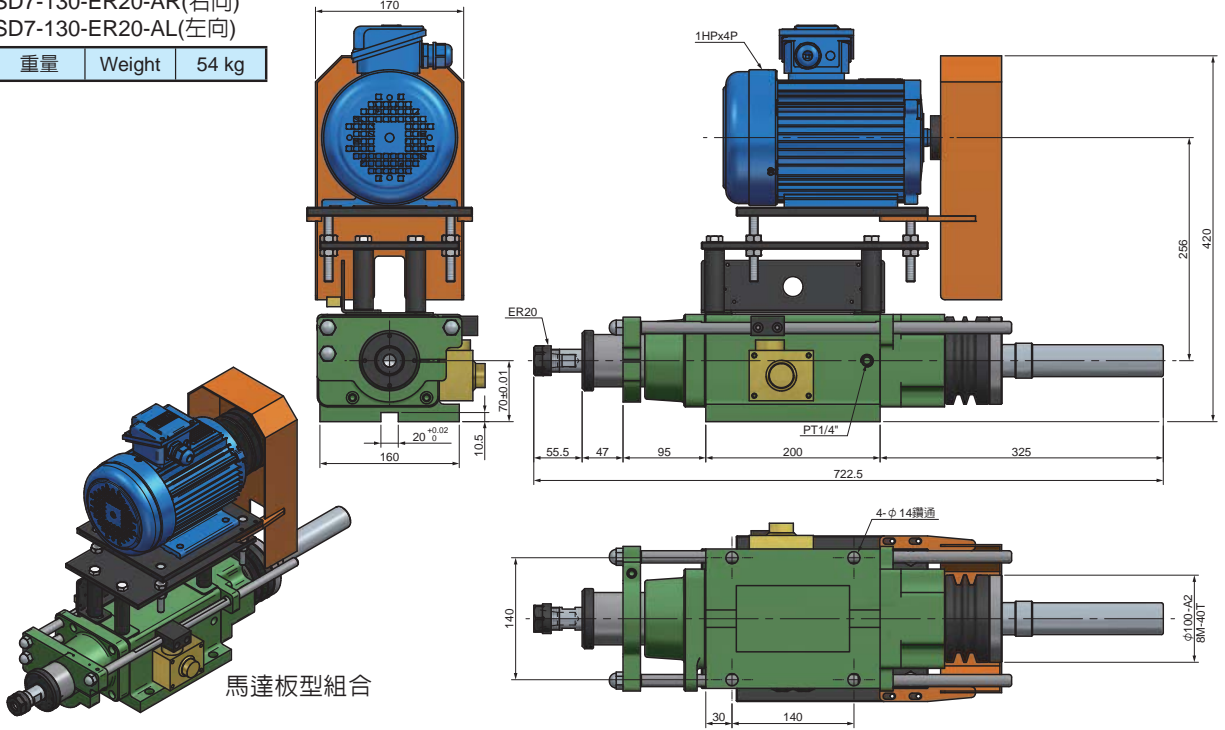

## 5072# SD8-150 鑽孔主軸頭 Drilling Head Units



馬達板型組合

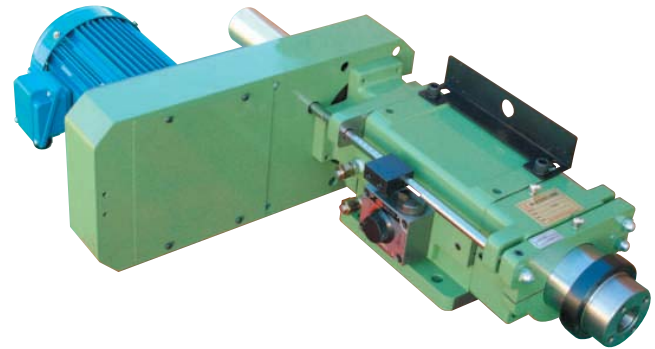

馬達盒組合

|       |                          |  |
|-------|--------------------------|--|
| 規格    | Model                    | SD8-150  |
| 鑽孔能力  | Drilling Capacity (S45C) | φ 35 mm  |
| 最大行程  | Max. Stroke              | 150 mm   |
| 最高轉速  | Max. RPM                 | 1500 RPM   |
| 推進壓力  | Propel Pressure          | 油壓 (H) 20~35 kg/cm <sup>2</sup>                            |
| 油缸面積  | Cylinder Diameter        | 前進 (F) 71.2 cm <sup>2</sup><br>後退 (B) 31.4 cm <sup>2</sup> |
| 馬力    | Horsepower, 3 Phase      | 2 HP, 220V / 380V  |
| 傳動皮帶  | Transmission Belt        | B2×φ 150, 8M×58T×56W                                       |
| 主軸軸承  | Spindle Bearing          | 6008Z, 32008<br>6010Z, 32010                               |
| 皮帶輪軸承 | Pulley Bearing           | 6013Z×1, 51213×1   |
| 前蓋油封  | Front Cover Seal         | TC90-110-12×1  |
| 活塞O型環 | Piston O-ring            | AP-100×3, AG-65×1, TC60-82-12×1                            |
| 前蓋O型環 | Front Cover O-ring       | AG-100×1, AP-90×2, AG-115×1                                |
| 後蓋O型環 | Back Cover O-ring        | AP-55×2, AG-100×1, AG-115×1                                |

Roundness: ≤ 0.003mm



**HARDY**

## 5072# SD8-150 鑽孔主軸頭 Drilling Head Units

SD8-150-ER40-R(右向)-MF  
SD8-150-ER40-L(左向)-MF

|    |        |       |
|----|--------|-------|
| 重量 | Weight | 96 kg |
|----|--------|-------|

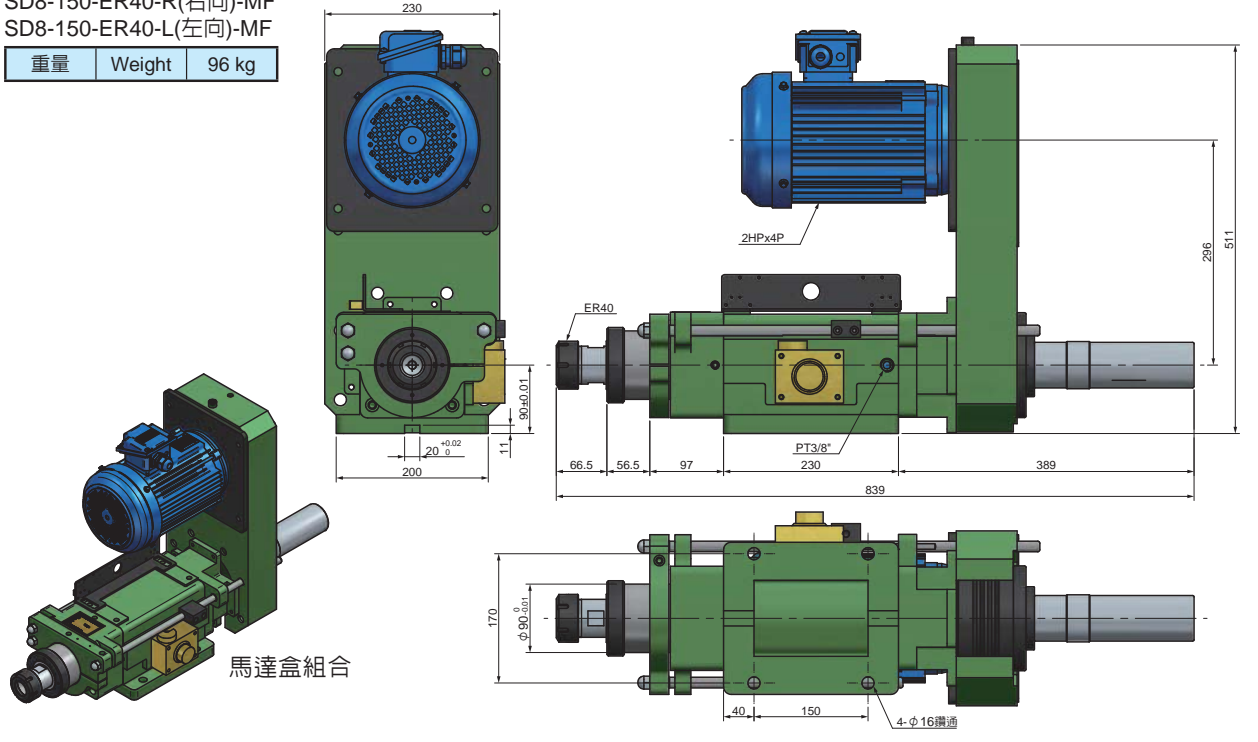

SD8-150-ER40-R(右向)-MB  
SD8-150-ER40-L(左向)-MB

|    |        |       |
|----|--------|-------|
| 重量 | Weight | 96 kg |
|----|--------|-------|

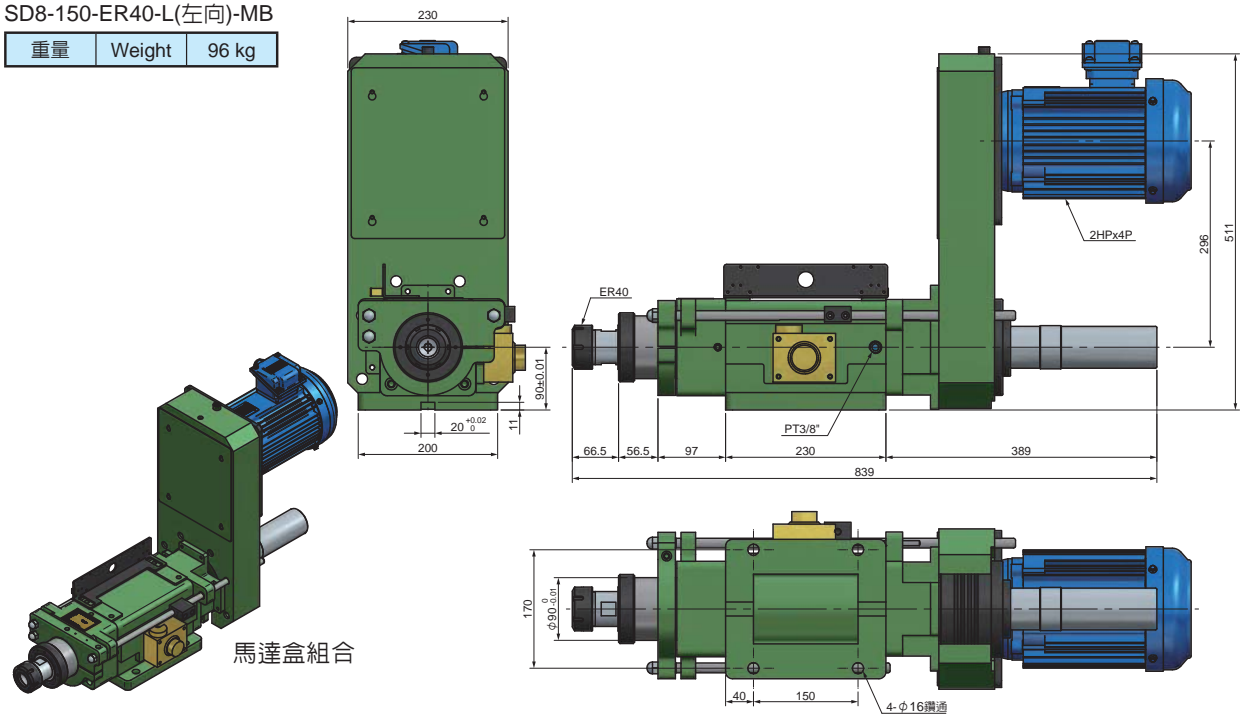



# 5072# SD8-150 鑽孔主軸頭 Drilling Head Units

SD8-150-ER40-AR(右向)  
SD8-150-ER40-AL(左向)

|    |        |        |
|----|--------|--------|
| 重量 | Weight | 103 kg |
|----|--------|--------|

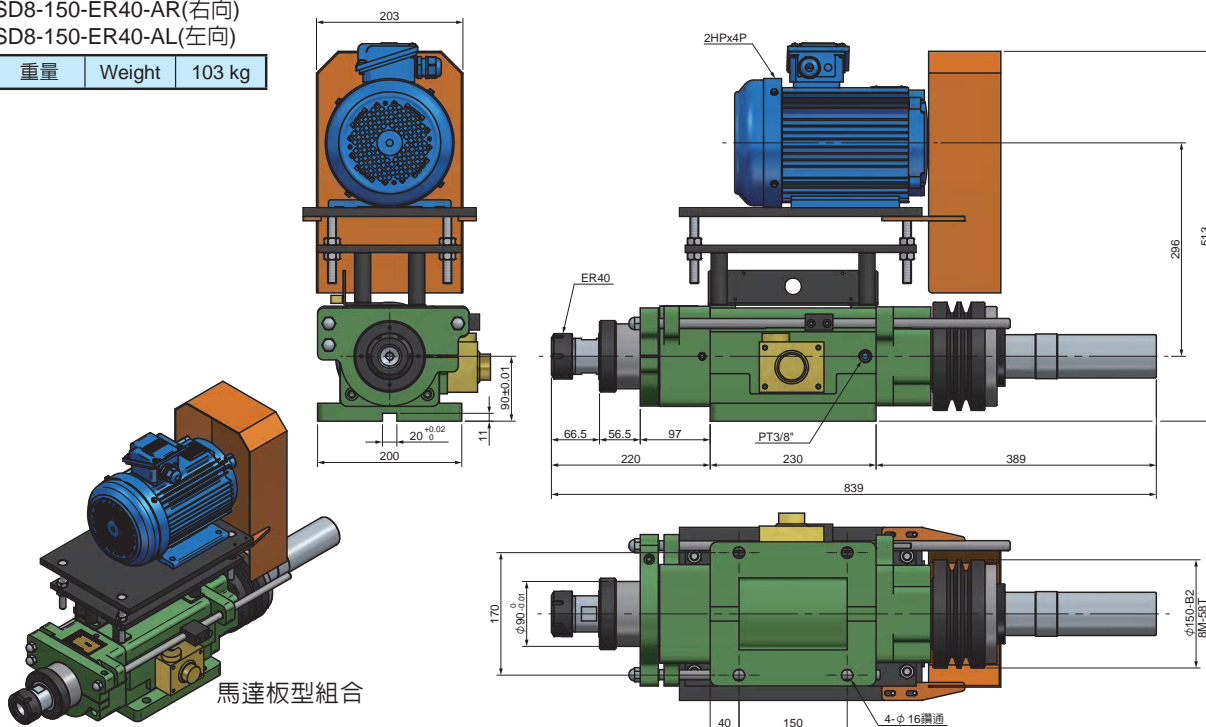

馬達板型組合

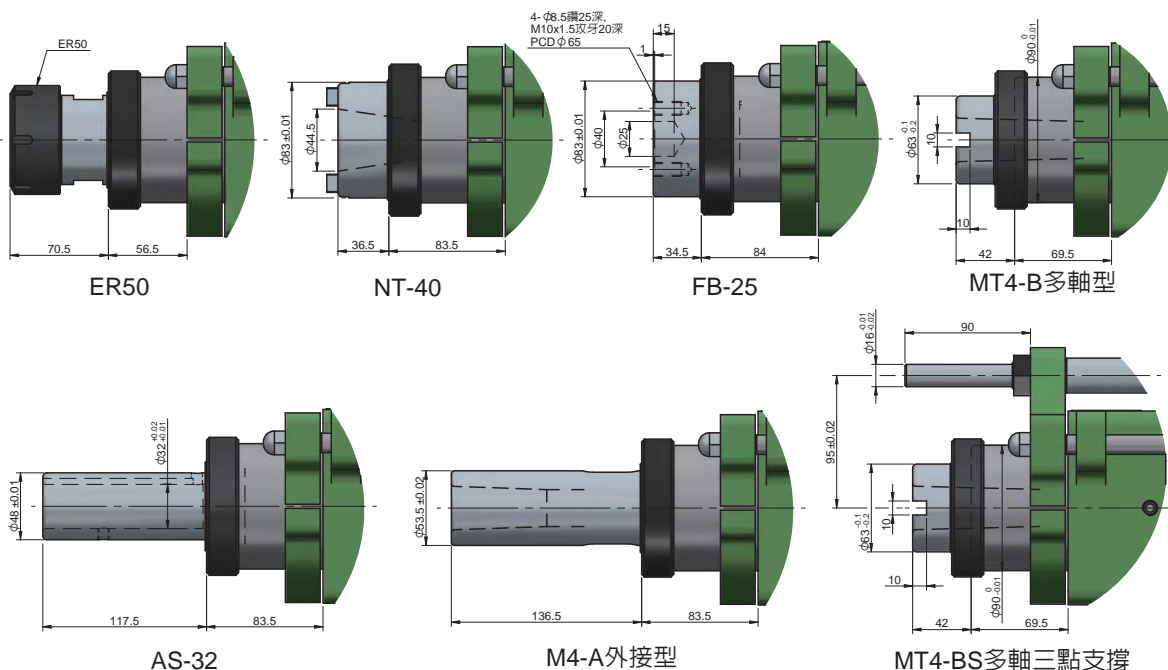



## 5073# SD09-120 油壓鑽孔/搪銑動力頭 Drilling/Milling Spindle Head-Hydraulic Type

| 規格    | Model                   | SD09                                   | SD09H            |
|-------|-------------------------|--|------------------|
| 鑽孔能力  | Drilling Capacity(S45C) | φ 25                                   |                  |
| 最大行程  | Max. Stroke             | 120mm                                  |                  |
| 最高轉速  | Max. RPM                | 3000                                   | 8000             |
| 推進壓力  | Propel Pressure         | 油壓(H)30~40kg/cm <sup>2</sup>           |                  |
| 油缸面積  | Cylinder Diameter       | 14.7cm <sup>2</sup> (缸徑φ50 : 心軸φ25)    |                  |
| 馬力    | Horsepower              | 2HP×4P                                 |                  |
| 主軸皮帶輪 | Spindle Pulley          | 5M-66T, φ 102.3×J×20                   |                  |
| 主軸軸承  | Spindle Bearing         | 6007Z×1 / 6006Z×1<br>32007×1 / 32006×1 | 7007×2<br>7006×2 |
| 皮帶輪軸承 | Pulley Bearing          | 6010ZZ×2                               |                  |
| 前蓋油封  | Front Cover Seal        | TC90-110-12×1                          |                  |
| 主軸油封  | Spindle Seal            | TC50-65-8×1                            |                  |

Roundness: ≤0.003mm

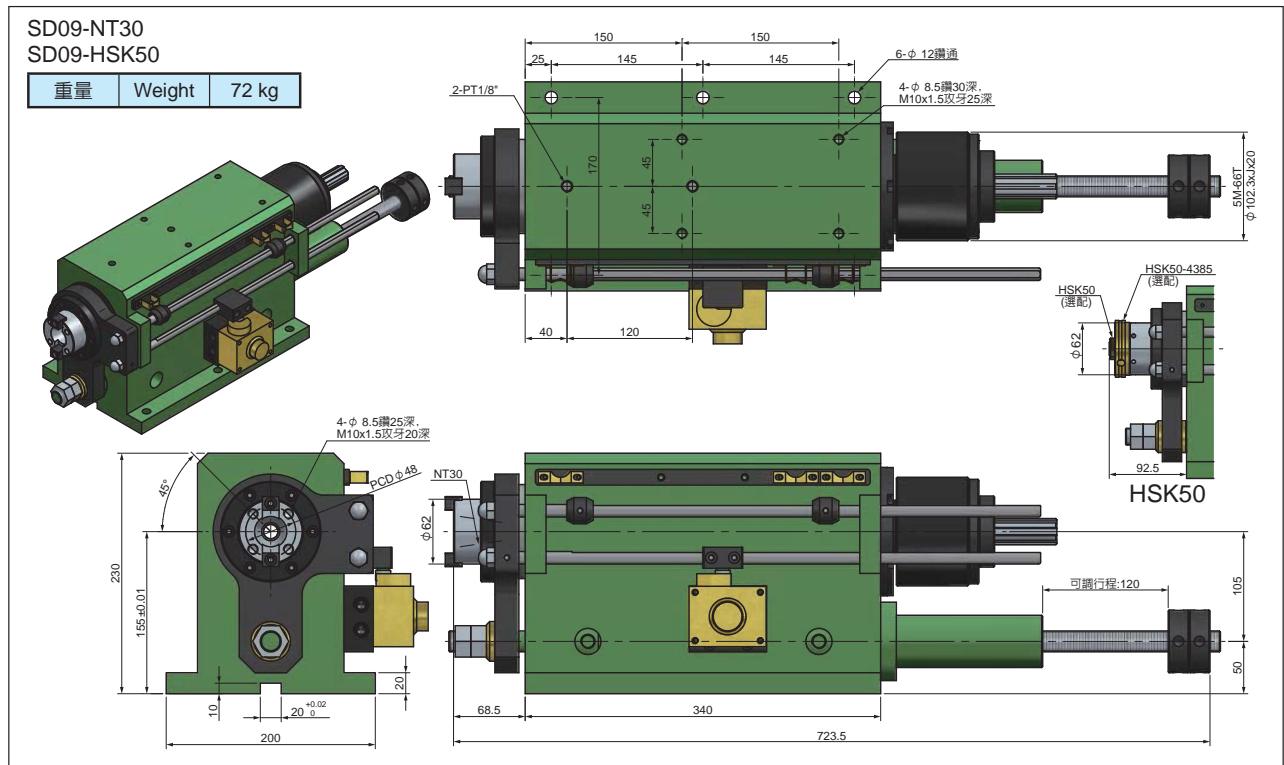

# 5073# SD09-120 油壓鑽孔/搪銑動力頭 Drilling/Milling Spindle Head-Hydraulic Type

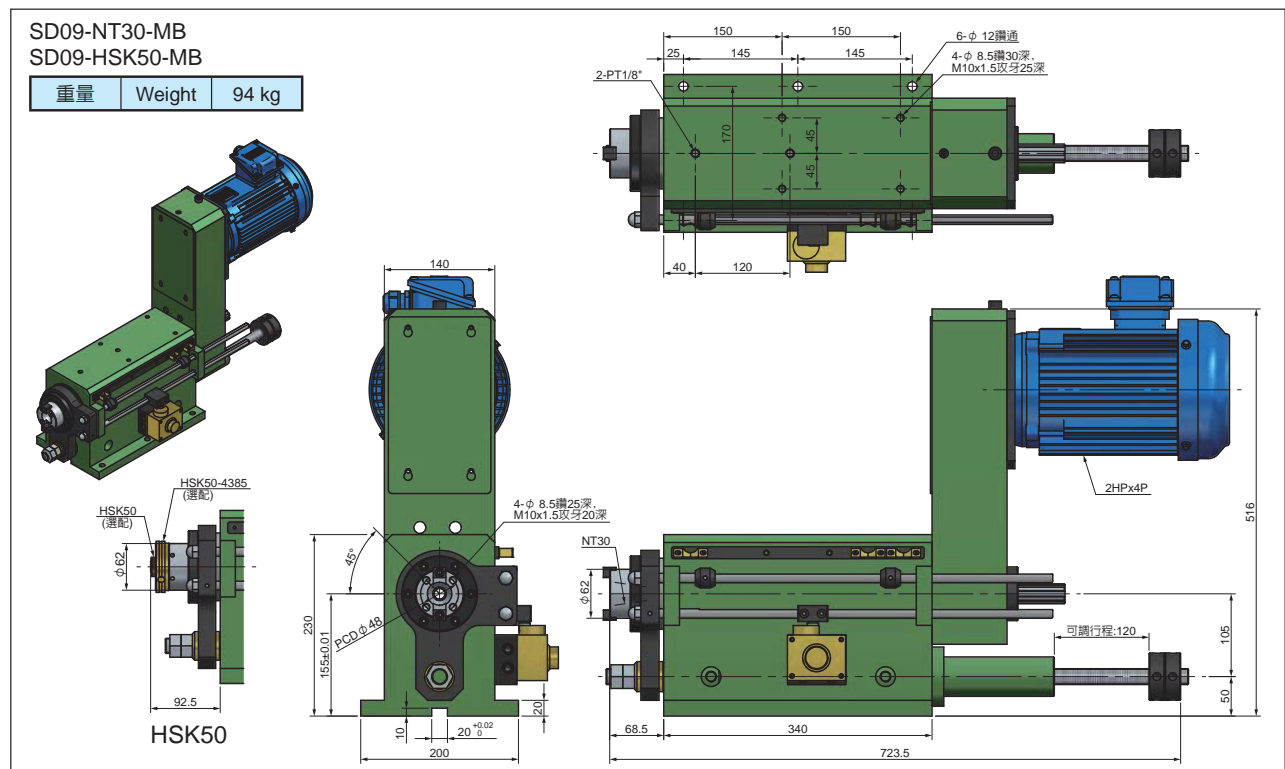
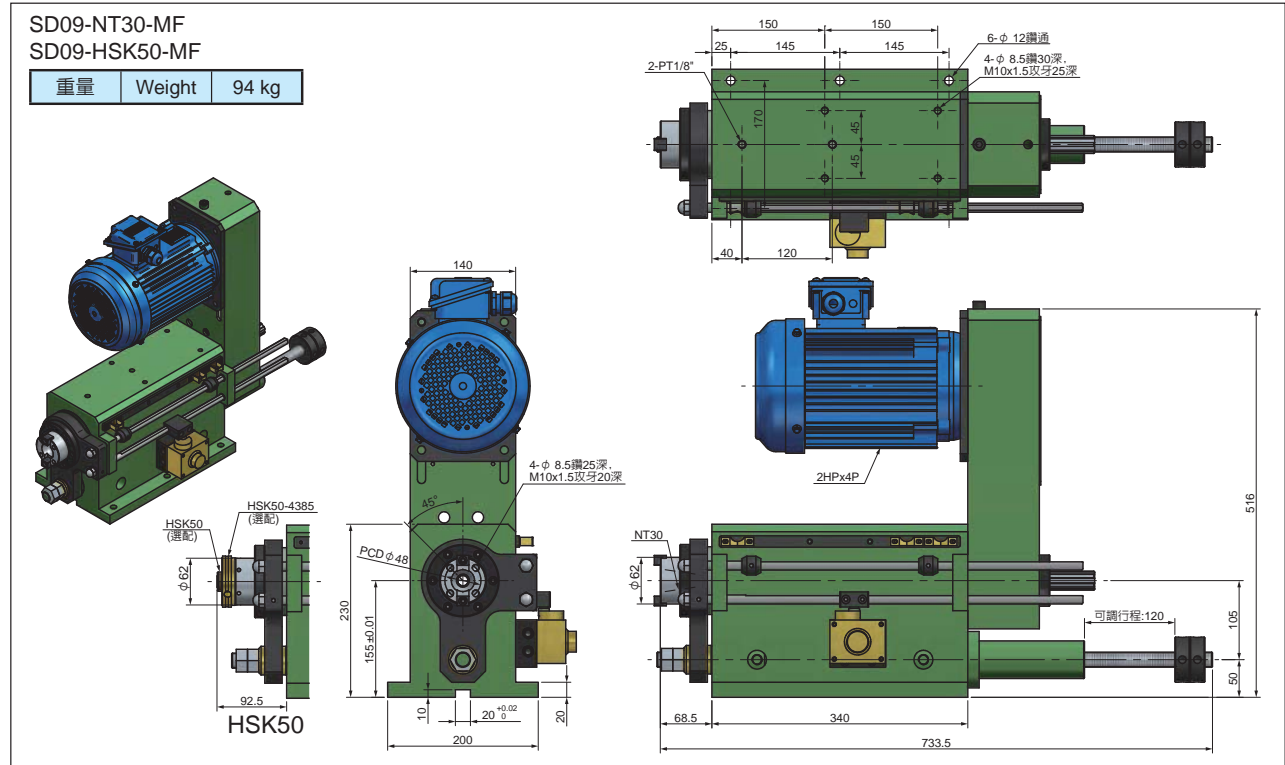





**HARDY**

## 5074# SD12-150 油壓鑽孔/搪銑動力頭 Drilling/Milling Spindle Head-Hydraulic Type

| 規格    | Model                   | SD12                                   | SD12H            |
|-------|-------------------------|--|------------------|
| 鑽孔能力  | Drilling Capacity(S45C) | φ 35                                   |                  |
| 最大行程  | Max. Stroke             | 150mm                                  |                  |
| 最高轉速  | Max. RPM                | 2000                                   | 6000             |
| 推進壓力  | Propel Pressure         | 油壓(H)30~40kg/cm <sup>2</sup>           |                  |
| 油缸面積  | Cylinder Diameter       | 21.2cm <sup>2</sup> (缸徑φ60 : 心軸φ30)    |                  |
| 馬力    | Horsepower              | 3HP×4P                                 |                  |
| 主軸皮帶輪 | Spindle Pulley          | 8M-54T, φ 133.6xJx25                   |                  |
| 主軸軸承  | Spindle Bearing         | 6011Zx1 / 6009Zx1<br>32011x1 / 32009x1 | 7011x2<br>7009x2 |
| 皮帶輪軸承 | Pulley Bearing          | 6211ZZx2                               |                  |
| 前蓋油封  | Front Cover Seal        | TC120-145-12x1                         |                  |
| 主軸油封  | Spindle Seal            | TC75-90-12x1                           |                  |

Roundness: ≤0.003mm

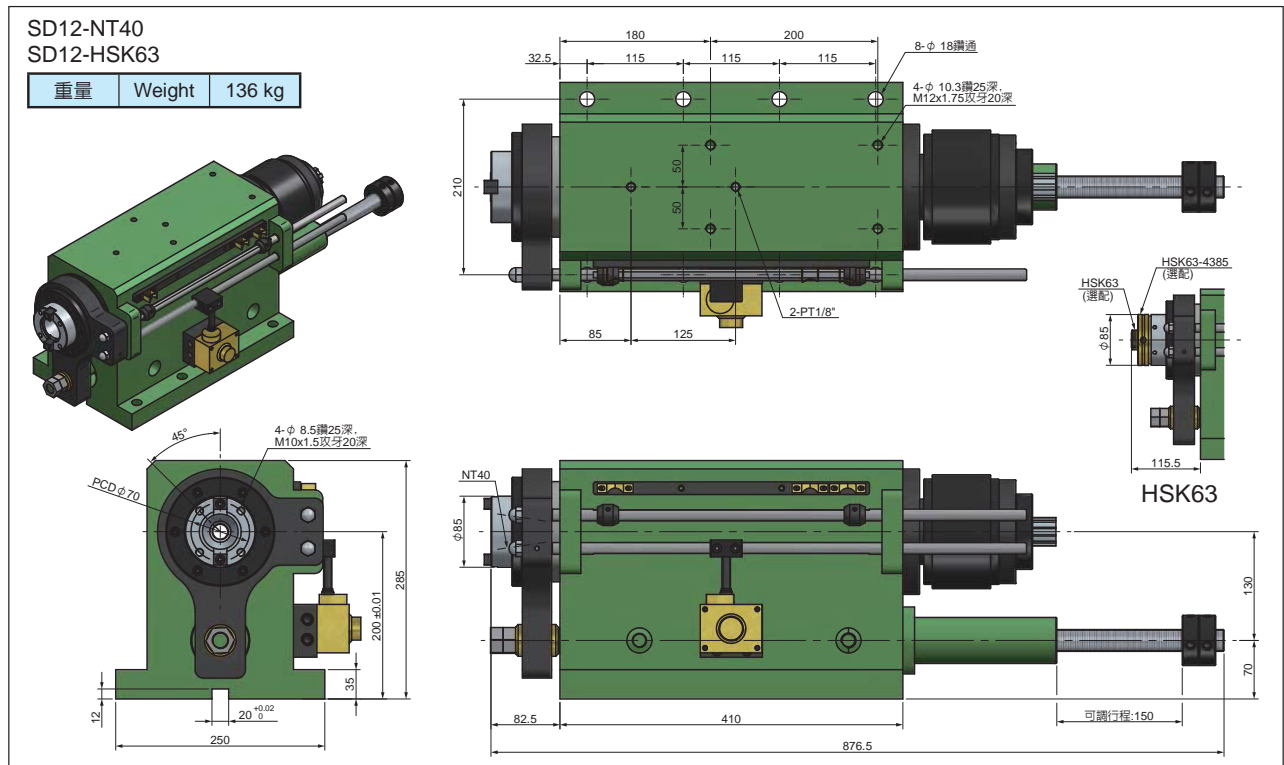



# 5074# SD12-150 油壓鑽孔/搪銑動力頭 Drilling/Milling Spindle Head-Hydraulic Type

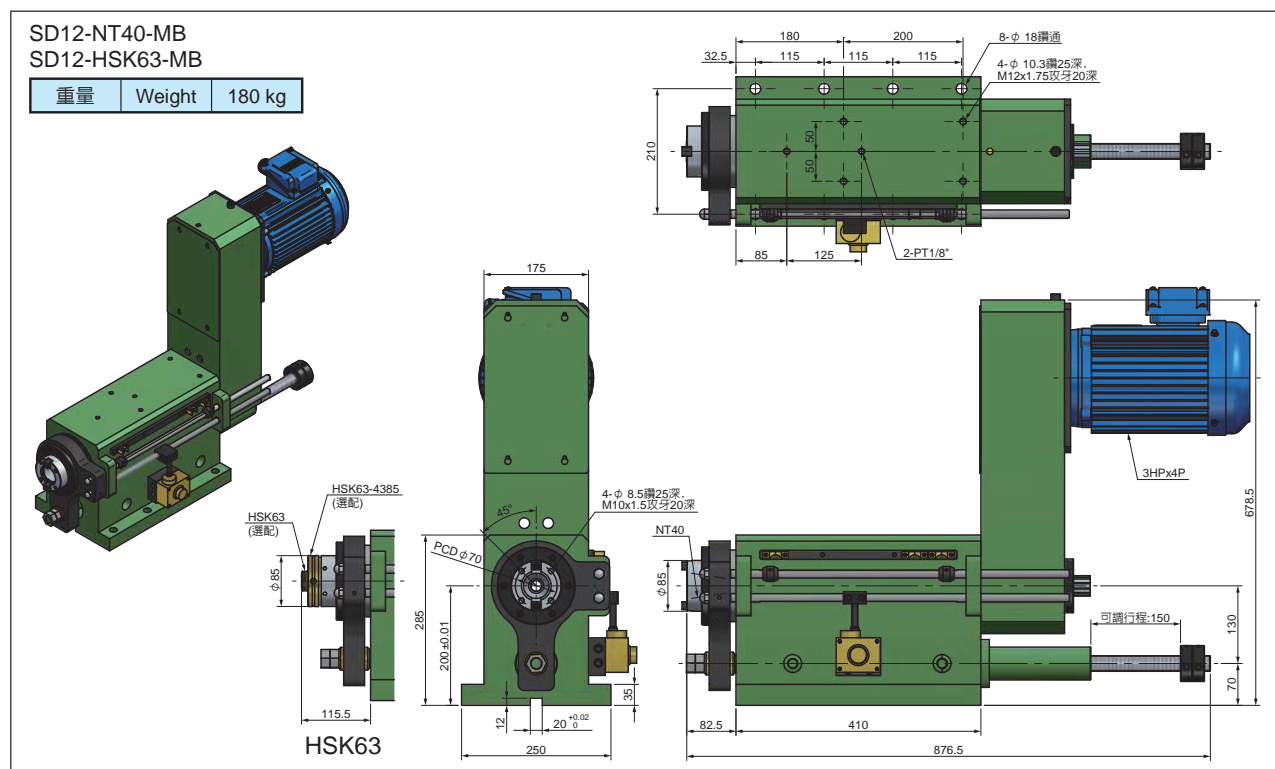
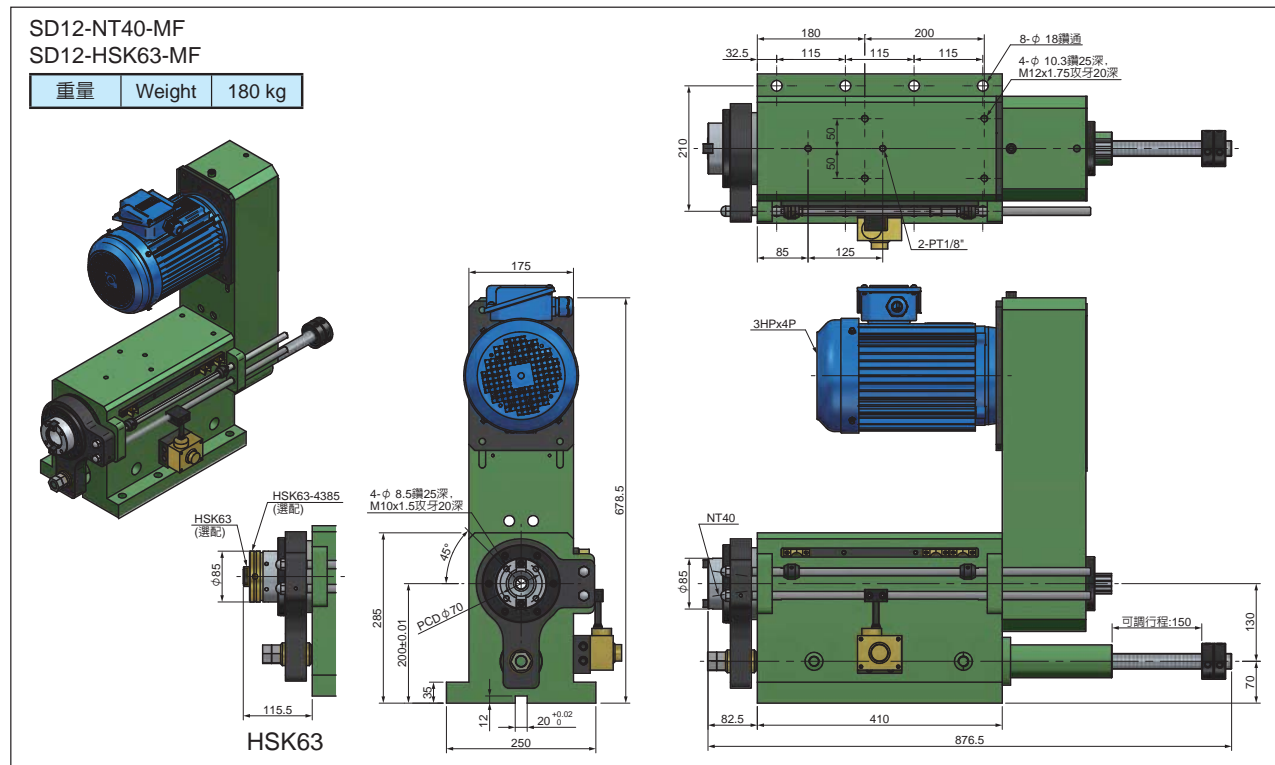



# 5075# SD15-150 油壓鑽孔/搪銑動力頭 Drilling/Milling Spindle Head-Hydraulic Type

